

Supplied with a solid refractory hearth with robust side and rear heat shields, the DS 300 complies with British Gas standards and is a fully failsafe system.

All sequences are visually displayed using neon indicators. On start-up the gas train, hoses and torches are tested for escaping gas. Leaks from any component will result in a continuously illuminated red neon and the main flow of gas will be prevented from entering the system.

PERFORMANCE			
GAS TYPE	RATE	BTU/HRS	KW
Natural Gas	2.18m <sup>3</sup> /h	80000	23.5
Propane	1.66kg/h	80000	23.5
Butane	1.70kg/h	80000	23.5

OPERATING GAS PRESSURES	
Natural Gas	20 mbar
Propane	35 mbar
Butane	28 mbar

*According to the Health & Safety at Work Act 1974, BS 4163 and COSHH Regulations it is mandatory that all fumes must be removed at source.*

- ◆ Please state type of gas when ordering ◆

## FLAMEFAST (UK) LTD

UNIT 2 · Labtec Street · Swinton · Manchester M27 8SE  
 Tel 0161 793 9998 · Fax 0161 793 0098  
 www.flamefast.co.uk · e-mail: sales@flamefast.co.uk

**THE DS 300 IS SUPPLIED WITH AN EASY-TO-USE SINGLE VALVE CONTROLLED RF 80 TORCH WHICH ALLOWS ONE-HAND OPERATION.**

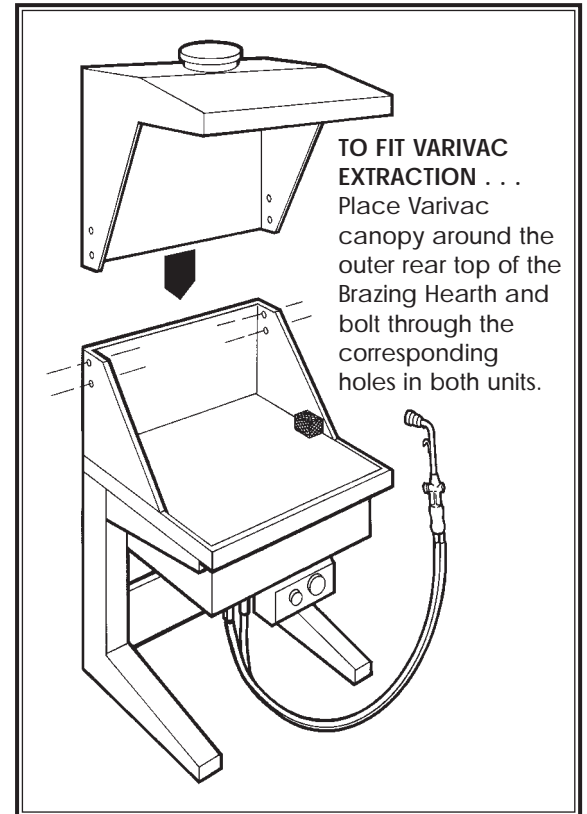

Electrics 120 watts - 220-240 volts single phase

Weight 122 Kg

### STANDARD EQUIPMENT

- ◆ Asbestos free heat resistant refractory hearth, side and rear heat shields.
- ◆ 5 Heat Reflective Blocks.
- ◆ Push button no volt release starter.  
Requires manual restart after power failure.
- ◆ RF 80 brazing torch.
- ◆ Colour coded reinforced gas and air hoses.
- ◆ Whisper quiet air blower fan.
- ◆ Push button electronic ignition.
- ◆ Auto gas leak proving system on start up.
- ◆ Indicator status lights.
- ◆ Gas non-return valve.
- ◆ Operating /Instruction manual.

### OPTIONAL EXTRAS

- ◆ RF 10 Fine Jewellery torch.
- ◆ Connection for second torch.
- ◆ 300mm revolving brazing table.
- ◆ Fume extraction to meet the requirements of COSHH Regulations.



E & O. E. MAR 02

