

ACID PICKLING BENCH

PRODUCT DATA SHEET

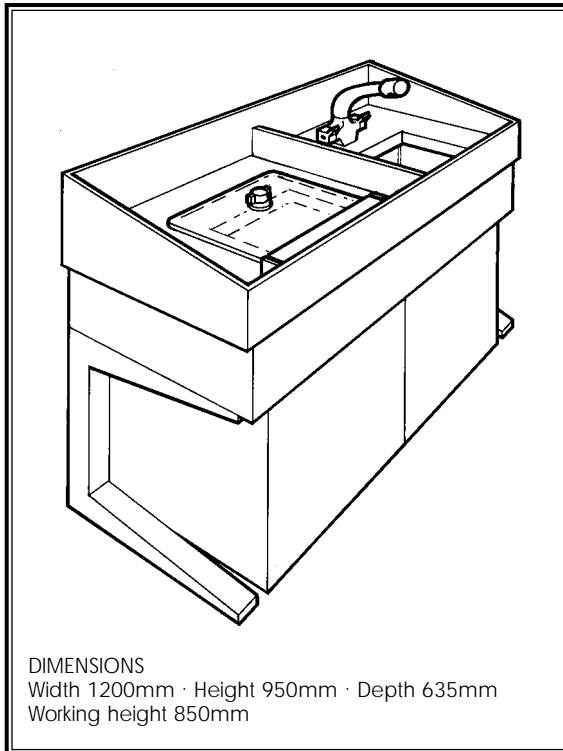

A unique dual purpose Pickling Bench which, for the first time, combines an acid bath with a glazed ceramic sink for hot and cold water.

The unique design, which complements the Flamefast range of Gas Equipment, ensures that from initial immersion of metals in acid to subsequent cleaning in water the student is totally protected from dangerous acid splashes.

The Pickling Bench worktop is manufactured from acid proof heat stabilised polypropylene and is self draining with front and side raised edges and backstand.

The safe evacuation of the acid bath is by means of a weir type drain tube and plug lock. This feeds directly into a dilution recovery trap.

According to the Health & Safety at Work Act 1974, BS 4163 and COSHH Regulations it is mandatory that all fumes must be removed at source.

◆ Please state type of gas when ordering ◆

FLAMEFAST (UK) LTD

UNIT 2 · Labtec Street · Swinton · Manchester M27 8SE
Tel 0161 793 9998 · Fax 0161 793 0098
www.flamefast.co.uk · e-mail: sales@flamefast.co.uk

PROVIDING TOTAL SAFETY FOR ALL ACID RELATED PROJECTS WITHIN CRAFT, DESIGN AND TECHNOLOGY DEPARTMENTS.

The acid bath is covered by a polypropylene lid with an inset clear view window and a locking hinge which allows the lid to be left in the upright position.

This upright lid acts as an anti-splash shield when transferring metals from the acid bath to the sink.

The lid also offers anti splash protection whilst working in the acid bath.

The glazed ceramic sink is a generous 455 x 350 x 205mm deep with a swivel arm mixer tap.

The Pickling Bench also provides ample undersink storage within the double doored lockable cupboard.

